

Field Terminated RJ45 Modular Plug Termination

1. General product information

These instructions provide the termination procedure for the Field Term. RJ45 Modular Plug for use in Modular Plug Terminated Links (MPTL). Wiring shown in instructions is for TIA 568B. See the CommScope Product Catalog for available configurations.

2. Tools required

- Cable jacket scoring tool (such as Xcelite® 2CSKY or JOKARI® No.1-Cat)
- Semi-Flush or Flush-cutting wire cutters (Lindstrom 8143 recommended)
- CommScope 3-231653-7 Hand tool with Pink Die & Jacknack tool

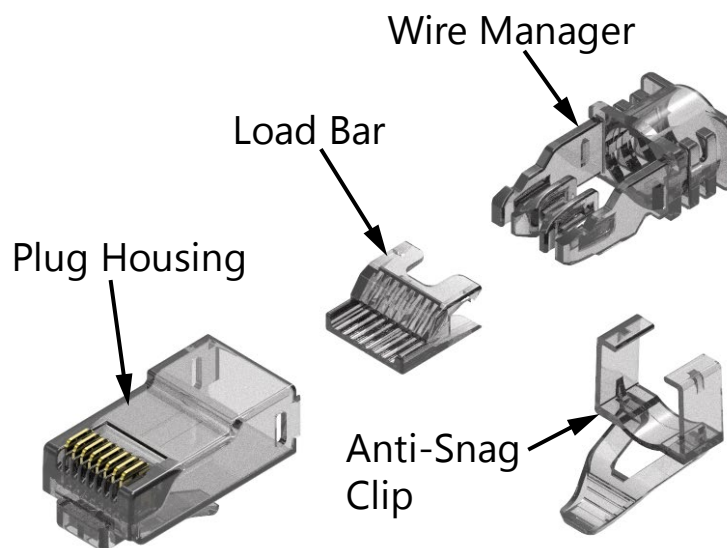

Field Term. RJ45 Modular Plug

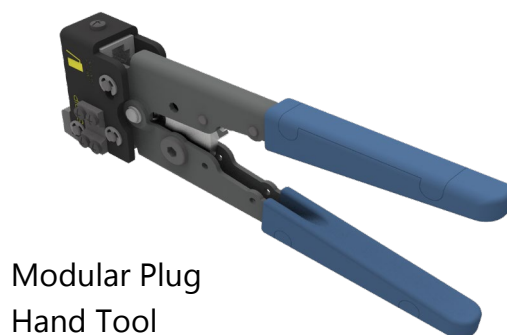

3. Parts list

Verify contents from the parts listed below:

CAT6A Field Term. RJ45 Modular Plug		Plug Housing Assembly	Wire Manager, Cat6A, 7.4mm bore	Load Bar, Small Wire, Clear Smoke	Anti-Snag Clip, Clear	3-231653-7 Hand tool with Pink Die & Jacknack tool
Material ID	Description					
760244127	FIELD TERM RJ45 MP CAT6A, PACK OF 25	25	25	25	25	
760244129	FIELD TERM RJ45 MP CAT6A, BAG OF 100	100	100	100	100	
760244131	FIELD TERM RJ45 MP CAT6A, BAG OF 100 +TOOL	100	100	100	100	1

CAT6 Field Term. RJ45 Modular Plug		Plug Housing Assembly	Wire Manager, Cat6, 6 mm bore	Load Bar, Large Wire, Clear	Anti-Snag Clip, Clear	3-231653-7 Hand tool with Pink Die & Jacknack tool
Material ID	Description					
760244128	FIELD TERM RJ45 MP CAT6, PACK OF 25	25	25	25	25	
760244130	FIELD TERM RJ45 MP CAT6, BAG OF 100	100	100	100	100	
760244132	FIELD TERM RJ45 MP CAT6, BAG OF 100 +TOOL	100	100	100	100	1

4. Cable Termination

1. Remove approximately 1 1/2 inches (38mm) of cable jacket. Cut away any between pair separator divider. Unwind and trim out any in wire pair separator tapes (if present).

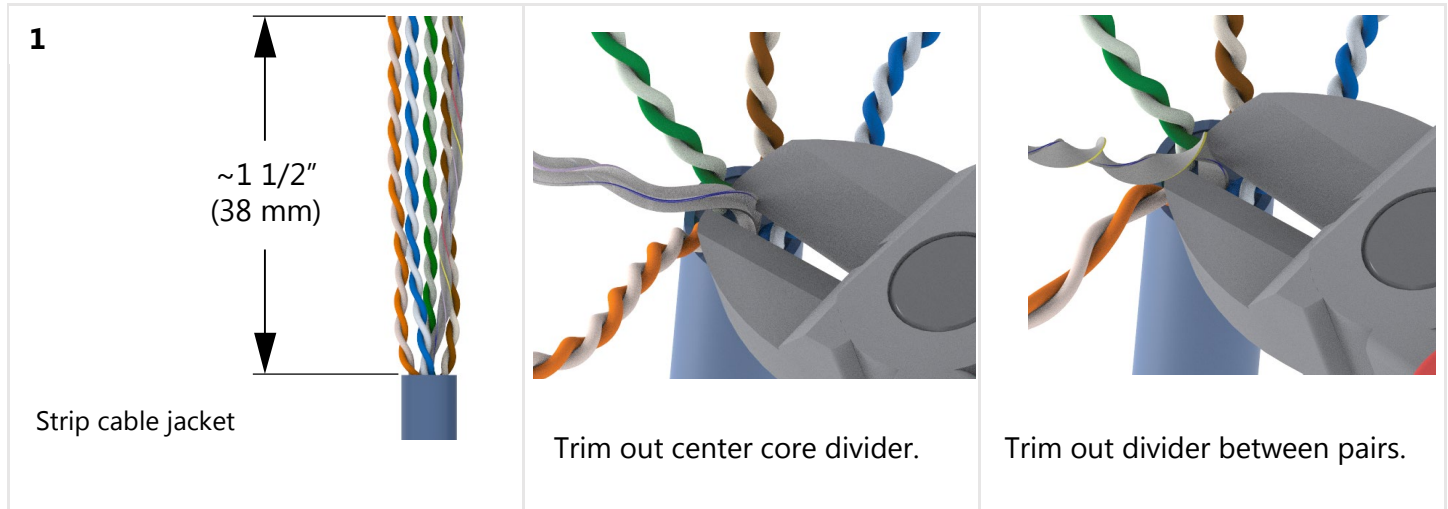

2. Pre-bend ends of pairs for easier insertion. Align wire pairs with Wire Manager, Orange and Brown pairs will be on latch side (flat side of manager with V-notched side wall) with either the Blue pair (2A) or the Green pair (2B) depending on cable end. The Orange pair (Pin 1) will be placed in the channel with the V-notched side wall. The Brown pair in the opposite outside channel. The Green & Blue Pairs will be in the middle channels.

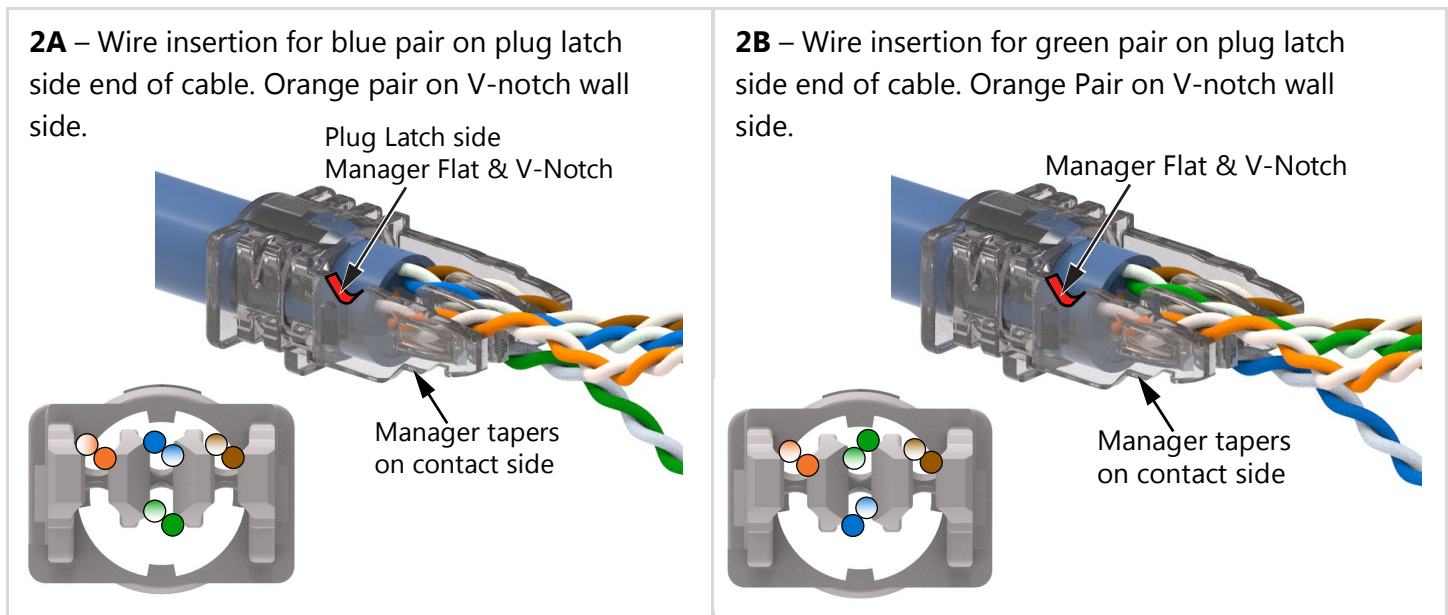

3. Fully insert cable until jacket or divider stops against pair channels; ~1/4 inch (6.4mm) of jacket will be exposed in front of manager jacket holding barrel. Align twist of each pair with vertical gates in wire manager channels, adding back twist as needed. Place each wire pair in vertical gates to hold pairs twist.

3A – Pairs in vertical gates for blue pair on plug latch side end of cable.

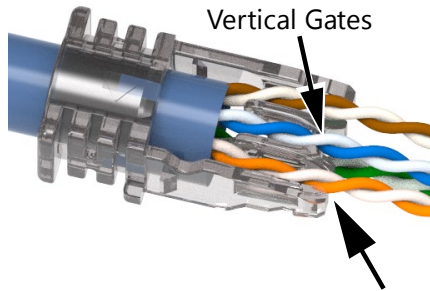

3B – Pairs in vertical gates for green pair on plug latch side end of cable.

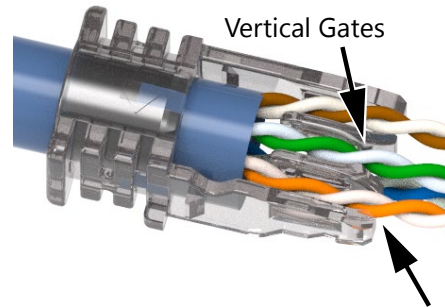

4. Clamp end of wire pair with Jacknack tool hook. Hold pair in vertical gate with fingers as you lightly pull and turn tool to untwist pair. Untwist fully until wires lay in their pair order for T568B. Twist should be maintained at the vertical gate on the wire manager. Repeat to untwist the other 3 pairs maintaining pair order at untwist.

4

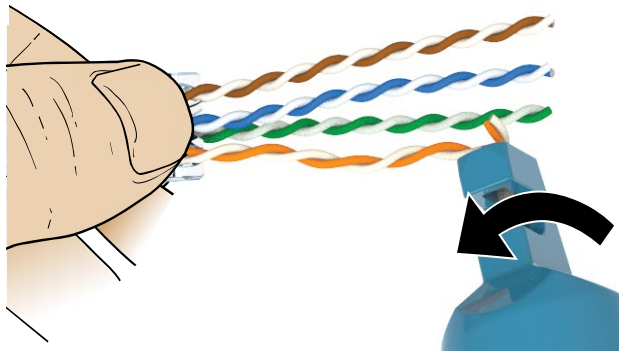

Clamp Jacknack to pair.

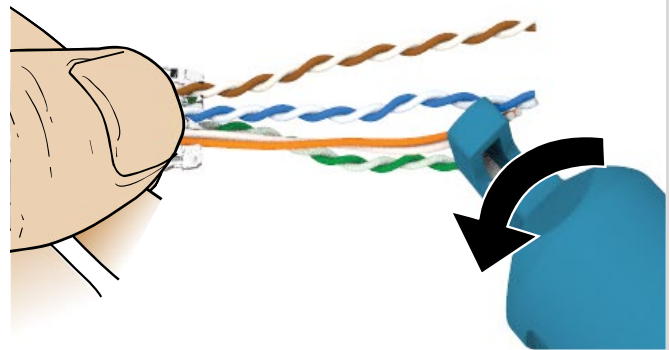

Lightly pull and untwist pair.

5. Fanout wires slightly and split the Green pair about the Blue pair to maintain pair order. The white wire in the orange pair (pin 1) will be at V-notch wall side.

5

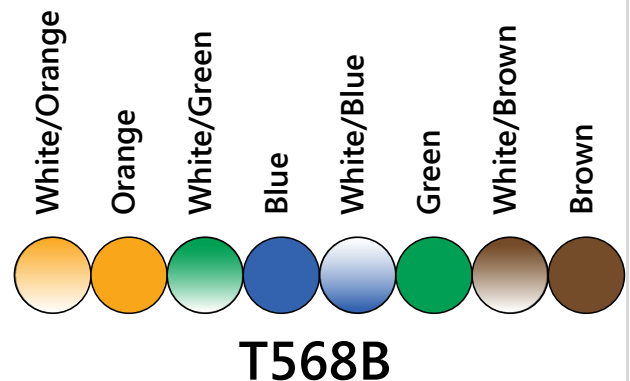
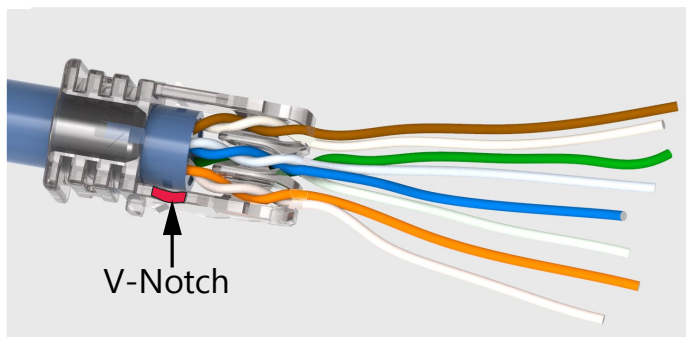

6. Be sure wires are in proper wiring order per T568B. Holding wires in vertical gates with fingers and use other hand fingers to grasp wires extended from gates. Work wires back & forth and up & down to straighten into a ribbon array form in pair order over ~1 inch (25mm) length.

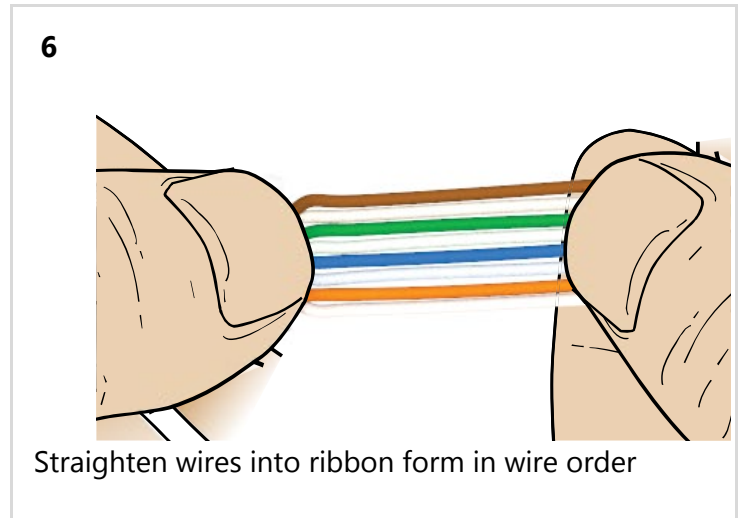

7. Trim straightened wire section with wire cutter to 1/2 to 1 inch (13mm-25mm) length.

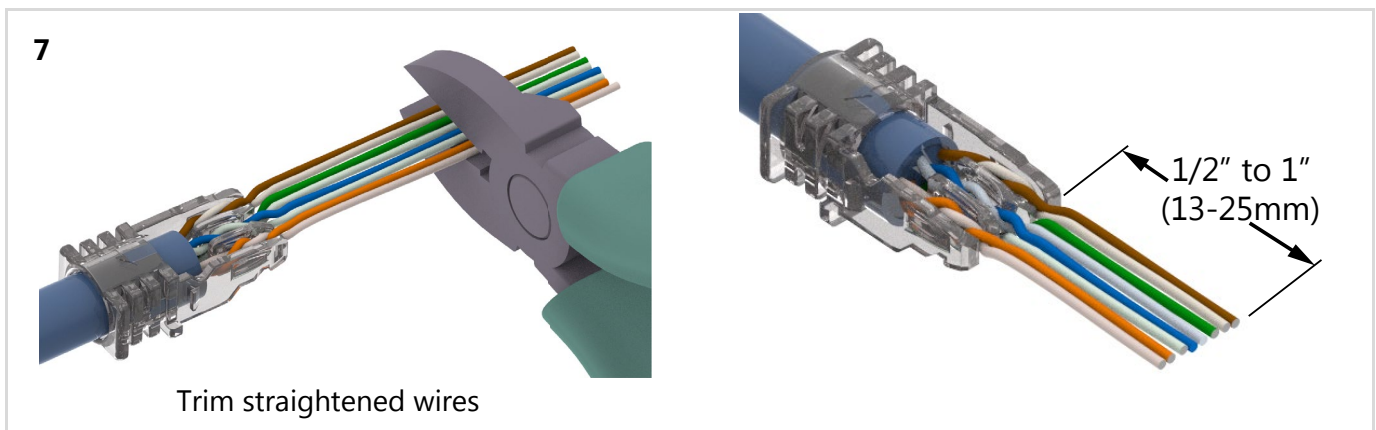

8. Holding wire array with fingers confirm wire order to T568B and align with Load bar. The flat side of the Load Bar with V-notch aligns with the flat side of the Wire Manager. Thread wires through holes in Load Bar and push Load Bar onto Wire Manager until it snaps in place

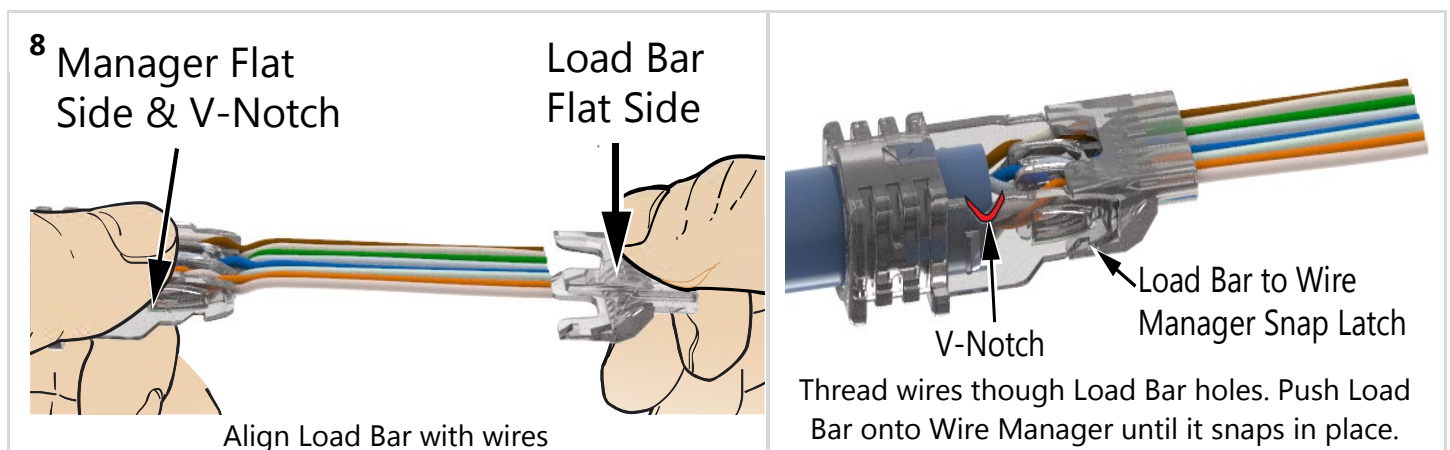

9. Trim wires flush with the end of load bar wire platform.
10. Apply plug housing assembly and seat to snap latches into place

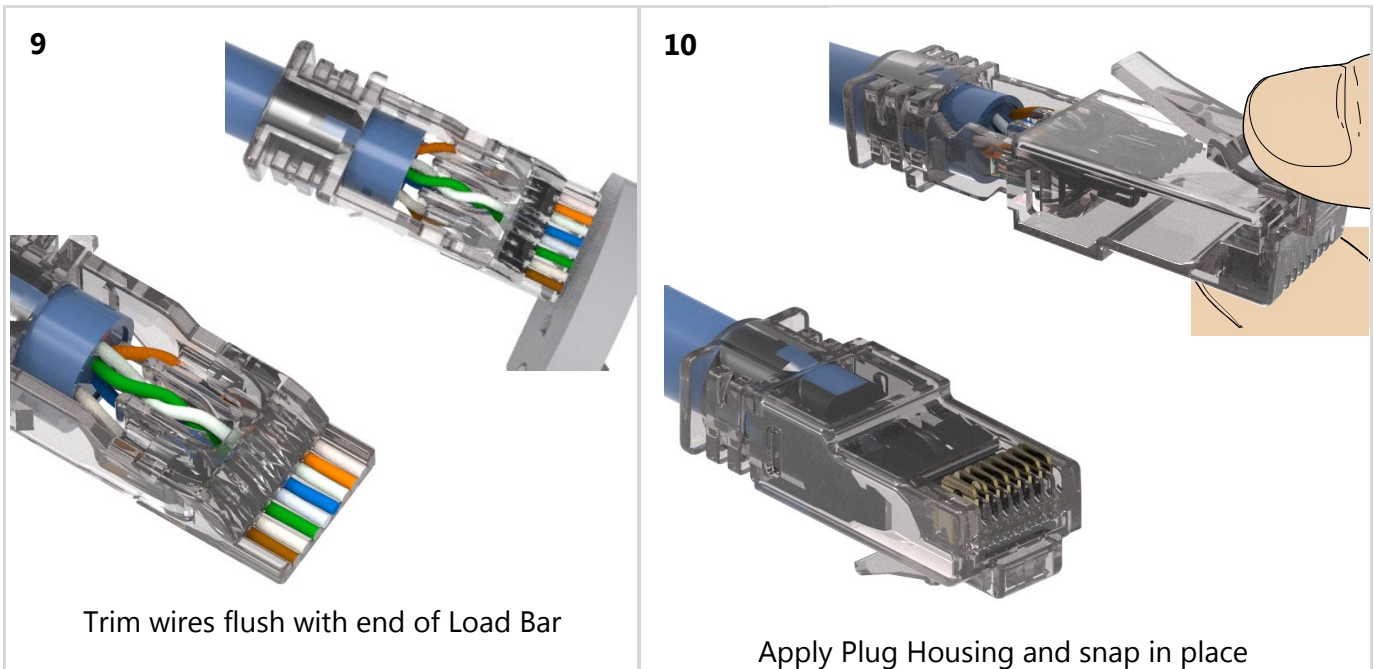

11. Read and follow instructions for CommScope Modular Plug Hand Tool (408-9767) for tool setup, contact termination, and contact inspection. Inserting plug into crimp tool with pink die set. Be sure plug housing is fully seated. Actuate tool lever handle to seat contacts.
12. Assemble Anti-Snag Clip by snapping clip onto rear portion of Wire Manager. Anti-Snag lever feature will go over top of the plug latch.

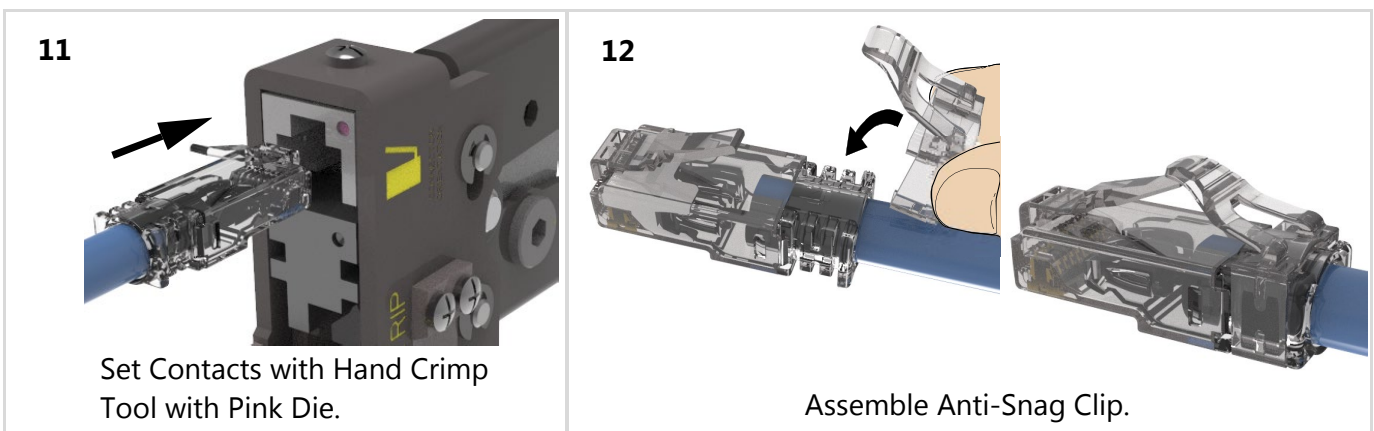

5. Revision history

- Rev. A – Initial release.